

Charge Air Coolers

Heat Transfer Technology from Bowman



BOWMAN[®]

100 YEARS OF HEAT TRANSFER TECHNOLOGY

Reducing temperature. Improving performance!

Bowman Charge Air Coolers

For turbocharged marine and land based engines

Charge air coolers cool the compressed combustion air from the turbocharger. By reducing the temperature, the incoming air is denser, enabling increased air mass to be supplied to the engine. The result is better combustion efficiency improved engine performance, reduced fuel consumption and emissions.

Bowman offer a comprehensive range of charge air coolers, which are suitable for marine and land based stationary engines up to 850kW. Based on Bowman's renowned 'shell and tube' design, these liquid cooled units enable temperatures to be precisely controlled.

Bowman charge air coolers are renowned for their quality, thermal efficiency and durability.

Applications include marine propulsion, combined heat and power generation, engine testing and pumps used in emergency fire protection systems.

For applications requiring higher flow rates of the cooling medium, single and two pass end covers are available in cast iron or naval brass.

Available for fast delivery, Bowman charge air coolers are also supported with a comprehensive range of replacement parts.



Marine and land based versions

Whether the cooling medium is salt water, fresh water or mineral rich/contaminated water, Bowman has a range of charge air coolers to suit virtually any marine or land based stationary engine application.

Outstanding reliability

Designed and built to the highest standards, Bowman units provide outstanding levels of reliability and durability.

High efficiency thermal transfer

Bowman charge air coolers deliver high levels of thermal transfer efficiency, due to the innovative design of the tube stack. To ensure maximum heat transfer performance, the units must be installed with the air and coolant in counter flow as shown on page 7.

Simple to maintain

The easily removable tubestack and end covers makes routine cleaning and maintenance simple and straightforward.





Titanium tube stacks

Titanium is the ultimate 'fit and forget' material for aggressive water conditions. Bowman now offer titanium tube stacks on many of our charge air coolers. See page 7 for more details.

Easy product selection

At Bowman, we have developed a computer programme to select the correct charge air coolers for your application. Simply by supplying us with the following information we can advise the correct unit;

- 1: Charge air mass flow rate in kg/min
- 2: Charge air pressure in bar g
- 3: Max. acceptable charge air pressure drop (if known) in kPa
- 4: Charge air cooler inlet and outlet temperature, or heat load & one temperature in kW and °C
- 5: Coolant temperature in °C
- 6: Type of coolant used, i.e. fresh, sea or glycol, including concentration
- 7: Coolant flow rate (if known) in l/min

Bespoke designs for specific engines

Within our range are a number of charge air coolers designed for specific engines. You can find out more information on these units by contacting our sales team.



Charge Air Coolers

Typical performance

The tables below show the performance that can be achieved from our Charge Air Coolers in either marine or land based operation.



Marine

Type	Charge Air Flow	Air Pressure Drop	Air Outlet Temp	Heat Rejection	Water Flow	Water Pressure Drop	Typical Engine Power
	(kg/min)	(kPa)	(°C)	(kW)	(l/min)	(kPa)	(kW)
EC120-4073-3	2.5	2.1	53.1	5.3	30	4.0	50
FC100-4074-2	4.3	3.0	56.7	9.1	50	6.3	90
FG100-4075-2	9.8	5.3	56.8	20.8	80	9.9	120
GL140-4076-2	15.4	7.3	56.4	32.9	140	10.4	175
GK190-4877-3	20.3	5.3	43.2	46.8	180	7.1	280
JK190-4078-3	30.1	7.4	41.5	70.3	270	7.8	365
PK250-4979-4	40.3	3.9	40.3	95.0	400	10.6	570
RK250-4980-4	60.0	7.9	35.2	146.6	550	8.3	850

Land

Type	Charge Air Flow	Air Pressure Drop	Air Outlet Temp	Heat Rejection	Water Flow	Water Pressure Drop	Typical Engine Power
	(kg/min)	(kPa)	(°C)	(kW)	(l/min)	(kPa)	(kW)
EC120-5173-3	2.5	2.1	53.1	5.3	30	4.0	50
FC100-5174-2	4.3	3.0	56.7	9.1	50	6.3	90
FG100-5175-2	9.8	5.3	56.8	20.8	80	9.9	120
GL140-5176-2	15.4	7.3	56.4	32.9	140	10.4	175
GK190-5177-3	20.3	5.3	43.2	46.8	180	7.1	280
JK190-5178-3	30.1	7.4	41.5	70.3	270	7.8	365
PK250-5979-4	40.3	3.9	40.3	95.0	400	10.6	570
RK250-5980-4	60.0	7.9	35.2	146.6	550	8.3	850

The above typical performance figures are based on an air inlet temperature of 180°C at 1.75 bar g and cooling water at 30°C.

Maximum air inlet temperature is 250°C. For higher temperatures please contact the sales department.

Maximum air inlet pressure is 5.5 bar g. (EC120 to GK190) and 4 bar g. (JK190 and RK250).

Bowman charge air coolers must not be operated without adequate water flow and must be mounted so that the water outlet is uppermost.

Charge Air Cooler Dimensions

EC120/FC100

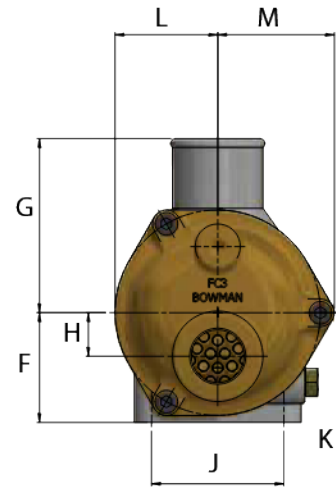
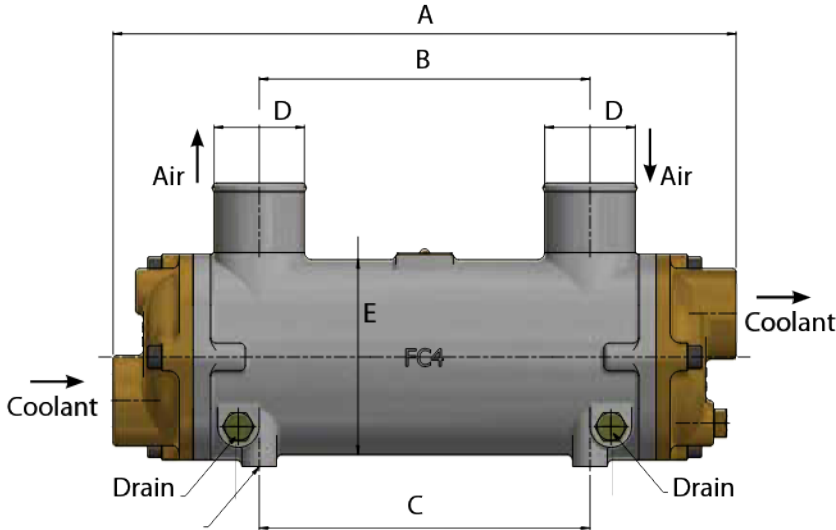

4 x mounting holes
 EC120 M6 x 10mm
 EC100 M8 x 12mm

Type	A	B	C	D	E	F	G	H	J	K	L	M	Weight
	mm	mm	mm	mm	mm	mm	mm	mm	mm	BSP	mm	mm	kg
EC120	346	212	190	52	94	55	90	20	52	3/4"	47	53	3.8
FC100	358	190	190	52	112	63	100	25	76	1"	59	67	6.7

FG100/GL140/GK190/JK190

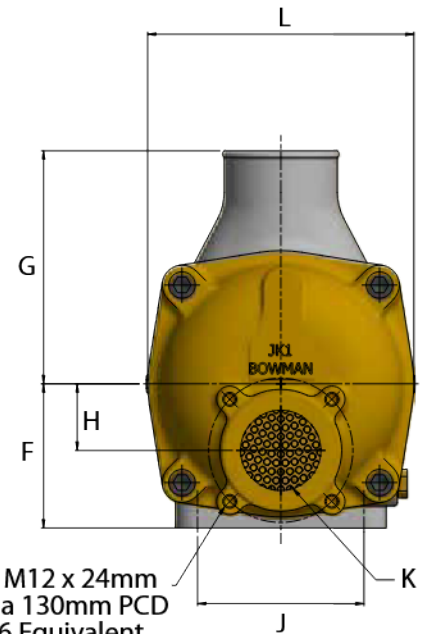
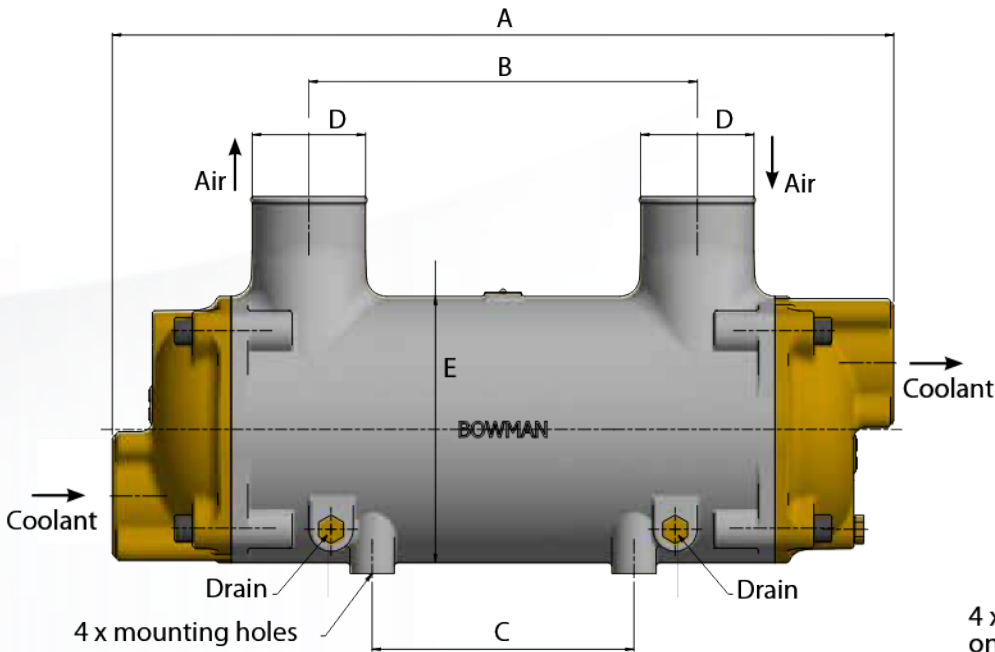

4 x M12 x 24mm
 on a 130mm PCD
 PN6 Equivalent
 (JK190 Only)

4 x mounting holes
 FG100 - M8 x 12mm
 GL140 - M10 x 15mm
 GK190 - M12 x 18mm
 JK190 - M16 x 32mm

Type	A	B	C	D	E	F	G	H	J	K	L	Weight
	mm	mm	mm	mm	mm	mm	mm	mm	mm	BSP	mm	kg
FG100	472	272	190	76	132	70	110	32	76	1 1/4"	132	10
GL140	502	272	108	76	170	90	130	38	120	1 1/2"	170	17
GK190	674	370	236	89	206	110	180	50	120	2"	206	36
JK190	704	350	236	102	240	130	210	60	150	2 1/2"	240	53

Charge Air Cooler Dimensions

PK250

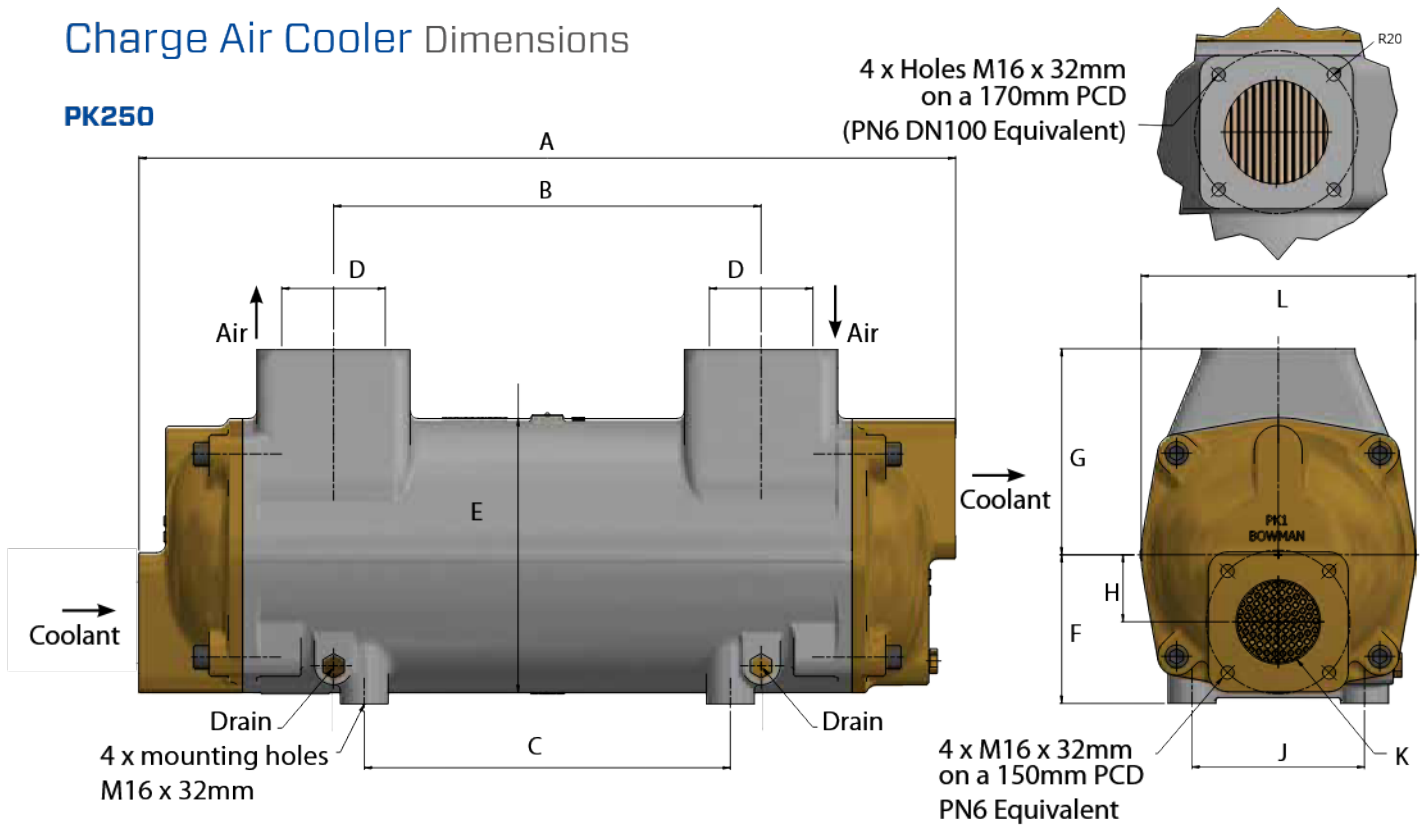

TYPE	A	B	C	D	E	F	G	H	J	K	L	Weight
	mm	mm	mm	mm	mm	mm	mm	mm	mm	BSP	mm	kg
PK250	852*	446	382	108	286	155	215	70	180	3"	286	97

* PK250-5979-4 (Land Based Version) - Dimension A = 900mm

RK250

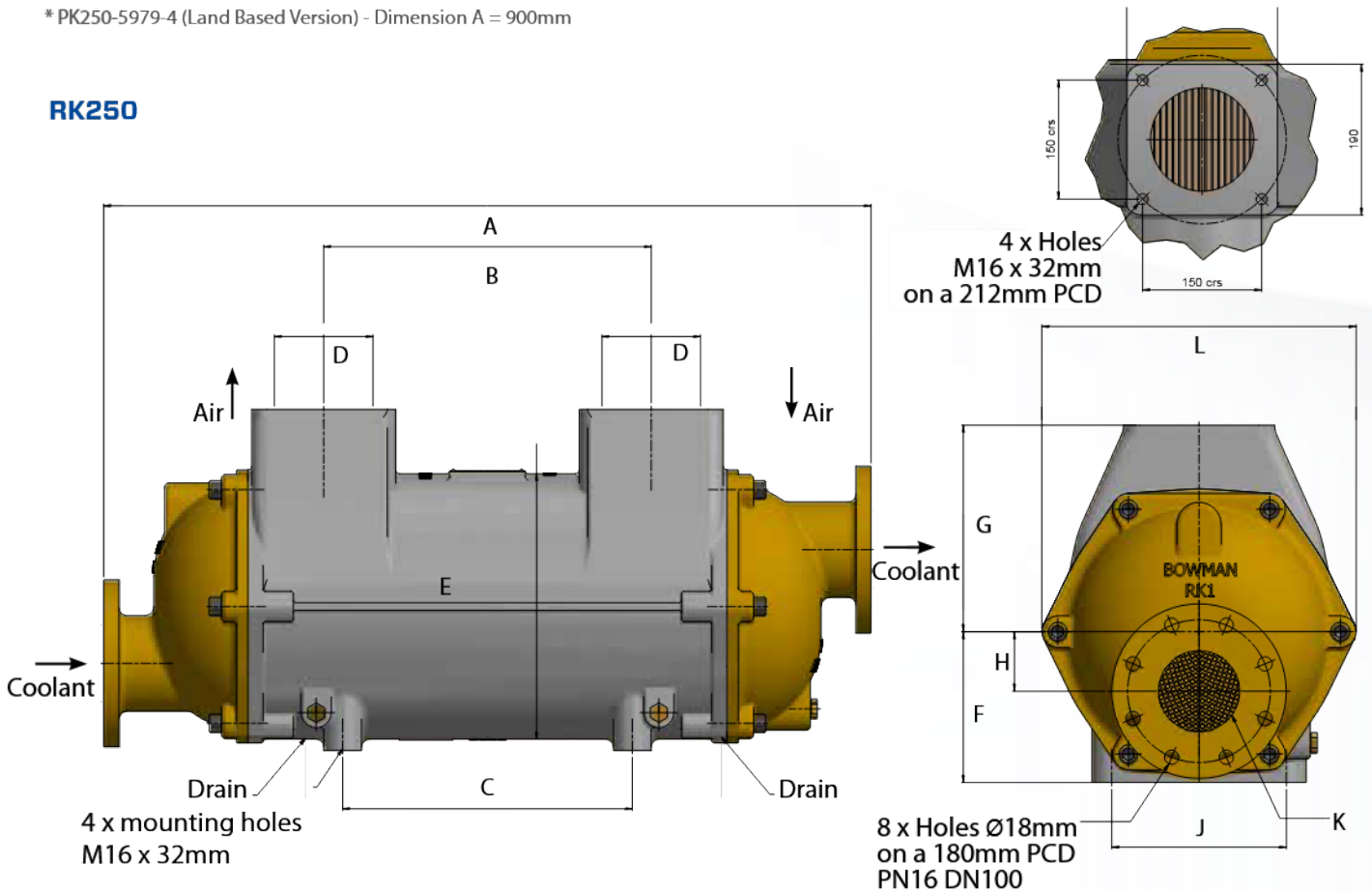

Type	A	B	C	D	E	F	G	H	J	K	L	Weight
	mm	mm	mm	mm	mm	mm	mm	mm	mm	BSP	mm	kg
RK250	1012	432	382	130	350	190	260	75	220	102	396	153

Installation

Bowman Charge Air Coolers must always be mounted so that the coolant outlet is uppermost (see diagrams below). They must not be operated without an adequate coolant flow and when used in conjunction with our header tank heat exchangers, they should be positioned in the circuit so that they always receive the full flow of the engine coolant pump.

IMPORTANT: to achieve maximum efficiency, Bowman charge air coolers must always be installed in counter flow – i.e. where the cooling medium flows in the opposite direction to the air being cooled. Please see the diagrams below.

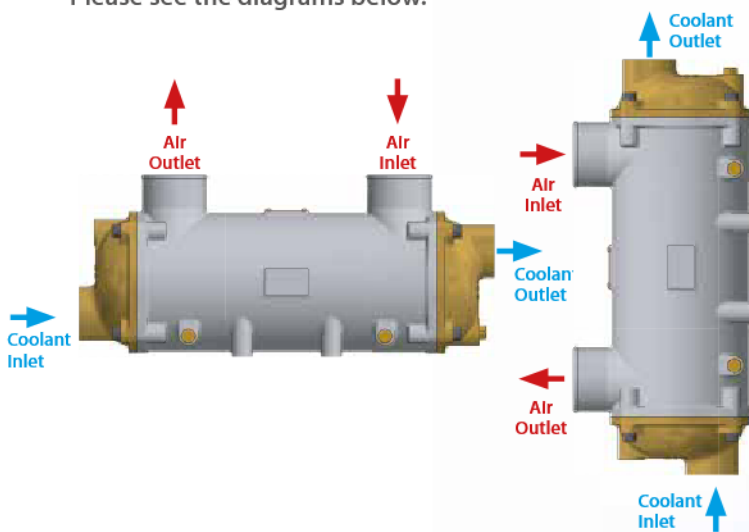

Titanium Tube Stacks

Titanium is the ultimate 'fit and forget' solution for any application where super aggressive water conditions exist, including salt water, or contaminated/mineral rich fresh water. It resists chemical attack indefinitely and also eliminates the possibility of 'galvanic reaction' between dissimilar materials – often the cause of premature failure in certain operating conditions.

For further guidance on installation, contact our sales team on +44 (0) 121 359 5401 or email: info@ej-bowman.com

Bowman titanium tube stacks come with a full 10 year guarantee on all titanium in contact with cooling water.



GUARANTEED
10
YEARS

Full 10 year guarantee on all titanium material in contact with cooling water.

Servicing the unit

By simply unscrewing the end cover retaining screws, the tube stack can be removed from its outer 'shell' for routine cleaning and maintenance. On reassembly, it is always recommended that the "O" rings are replaced to ensure a reliable, water tight seal.



Replacement Parts

A comprehensive range of replacement parts is available for all Bowman charge air coolers. This includes end covers, "O" ring seals, tube stacks, bodies and end cover fixings.

Total Engine Cooling Solutions

For nearly 100 years, Bowman has provided efficient, reliable cooling solutions for normally aspirated and forced induction engines. During that time the company has amassed a wealth of expertise and can provide a complete cooling solution for both marine and land based stationary engines, including:

Header Tank Heat Exchangers

Bowman's unique design combines high efficiency engine cooling, with long life durability. Suitable for engines up to 1800kW.



Exhaust Gas Heat Exchangers

Recover 'waste heat' from the engine's exhaust stream.



Engine & Gearbox Oil Coolers

A range of compact units suitable for engine or transmission oil cooling.



Fuel Coolers

Bowman in line plate fuel coolers are compact, easy to install and suitable for use with all fuel types – including ethanol rich fuels.



All material contained in this brochure is the intellectual property of EJ Bowman (Birmingham) Ltd. It is protected under copyright and may not be reproduced without prior written consent of the company.

A world of applications

Bowman charge air coolers have been tested and proven in some of the most extreme operating conditions around the world, from icy depths of a Northern Canadian winter, to the searing heat of an Australian summer, plus just about everything in between. Here are just a few examples:



Marine Engineering

In Portugal, Bowman FG100 charge air coolers have been used to convert two John Deere engines for marine use. The installation, on the Catamaran 'Independencia', helped reduce temperatures in the engine room from over 50°C to just 25°C.



Power Generation

In Canada, Bowman FG100 charge air coolers are playing a vital part in a cogeneration system that has halved energy costs in the remote community of Fort Providence in the Northwest Territories, where temperatures in winter can fall to -40°C.



Irrigation Systems

Bowman GK190 charge air coolers are being used to cool Iveco irrigation pumps sets at a 165 hectare vineyard in New South Wales, Australia, where, with vines 800 metres long, particularly high operating pressures and temperatures are experienced.



Active Fire Protection

This leading Australian fire pump manufacturer exclusively specifies Bowman charge air coolers for all of its fire pumps, with hundreds of units now installed throughout the country.



With over 50 years' experience cooling marine engines, generating sets, co-generation equipment, active fire protection systems and engine test equipment, you can rely on Bowman charge air coolers to deliver optimum charge cooling efficiently and reliably, whatever the operating conditions.

Only Genuine Bowman products are sold by Bowman Australia which is an Australian registered company completely separate to and wholly independent of the company that manufactures the products which is EJ Bowman Birmingham Ltd the actual and only manufacturer of genuine Bowman Heat Exchangers and Coolers. The relationship between both companies is that of manufacturer and distributor.

BOWMAN®

100 YEARS OF HEAT TRANSFER TECHNOLOGY

1800 915 825

Expert advice: Qualified Mechanical & Heat Transfer Engineers are available here in Australia to answer your queries, assist with trouble shooting, solve your Heat Transfer problems and assist with the design and selection of the best Bowman product for your application.

Maintenance Workshops: When you buy our Bowman Heat Exchangers we support you with the backup of maintenance workshops East and West coasts of Australia

PERTH

19 Tacoma Circuit
Canning Vale
WA 6155
08 9455 5933

BRISBANE

18 Pradella Street
Darra
QLD 4076
07 3375 1544

MELBOURNE

10 Gabrielle Court
Bayswater North
VIC 3153
03 9761 7766



FM38224

Info@bowmanheatexchangers.com.au

G21